



950 Series Sealant Gun

309968D

ENG

For dispensing sealant from caulking tubes. For professional use only.



Important Safety Instructions

Read all warnings and instructions in this manual.
Save these instructions.
More warnings.

Models

Palm Grip Gun:

2.5 oz. (C04074) and 6 oz (C04087)

Pistol Grip Gun:







2.5 oz. (C04076), 6 oz. (C04090), and 12 oz. (C04068)

Contents

Warnings	3	Service	7
.....	3	Sealant Gun Body Disassembly	
Installation.....	4	(C04093).....	7
Manual Applications	4	Gun Handle Disassembly (C04079)	7
Automatic Applications.....	4	Sealant Gun Reassembly (C04093)	7
Air Requirements	4	Gun Handle Assembly (C04079).....	7
Operation.....	4	Parts.....	8
Air-Powered Sealant Guns	4	Technical Data	10
Manual Sealant Guns.....	4	Accessories.....	10
Gun Tip/Nozzle Safety.....	4	Notes	11
Pressure Relief Procedure.....	5	Graco Standard Warranty.....	12
Troubleshooting.....	6		

Warnings

The following warnings are for the setup, use, grounding, maintenance and repair of this equipment. The exclamation point symbol alerts you to a general warning and the hazard symbol refers to procedure-specific risks. When these symbols appear in the body of this manual refer back to these Warnings. Product-specific hazard symbols and warnings not covered in this section may appear throughout the body of this manual where applicable.

 <h1 style="margin: 0;">WARNING</h1>	
 	<p>PRESSURIZED EQUIPMENT HAZARD</p> <p>Fluid from the equipment, leaks, or ruptured components can splash in the eyes or on skin and cause serious injury.</p> <ul style="list-style-type: none"> • Follow the Pressure Relief Procedure when you stop spraying/dispensing and before cleaning, checking, or servicing equipment. • Tighten all fluid connections before operating the equipment. • Check hoses, tubes, and couplings daily. Replace worn or damaged parts immediately.
 	<p>EQUIPMENT MISUSE HAZARD</p> <p>Misuse can cause death or serious injury.</p> <ul style="list-style-type: none"> • Do not operate the unit when fatigued or under the influence of drugs or alcohol. • Do not exceed the maximum working pressure or temperature rating of the lowest rated system component. See Technical Data in all equipment manuals. • Use fluids and solvents that are compatible with equipment wetted parts. See Technical Data in all equipment manuals. Read fluid and solvent manufacturer's warnings. For complete information about your material, request MSDS from distributor or retailer. • Do not leave the work area while equipment is energized or under pressure. Turn off all equipment and follow the Pressure Relief Procedure when equipment is not in use. • Check equipment daily. Repair or replace worn or damaged parts immediately with genuine manufacturer's replacement parts only. • Do not alter or modify equipment. • Use equipment only for its intended purpose. Call your distributor for information. • Route hoses and cables away from traffic areas, sharp edges, moving parts, and hot surfaces. • Do not kink or over bend hoses or use hoses to pull equipment. • Keep children and animals away from work area. • Comply with all applicable safety regulations.
	<p>PERSONAL PROTECTIVE EQUIPMENT</p> <p>You must wear appropriate protective equipment when operating, servicing, or when in the operating area of the equipment to help protect you from serious injury, including eye injury, hearing loss, inhalation of toxic fumes, and burns. This equipment includes but is not limited to:</p> <ul style="list-style-type: none"> • Protective eyewear, and hearing protection. • Respirators, protective clothing, and gloves as recommended by the fluid and solvent manufacturer.

Installation

Topics Covered in this Chapter

- ◆ Manual Applications
- ◆ Automatic Applications
- ◆ Air Requirements

Note

Read this manual thoroughly before installing sealant gun.

Inspect sealant gun for shipping damage. If damaged, notify the carrier immediately.

Manual Applications

The palm and pistol grip sealant guns are used in hand-held applications.

1. Secure gun in a way that allows proper routing of air hose and fitting.
2. Make sure gun does not impede movement of person.
3. Tighten hose connections before operating equipment. The air-powered sealant gun can be supplied air from any standard air pump.
4. Do not exceed maximum working pressure of sealant gun.

Automatic Applications

The palm grip and pistol grip sealant guns are not designed for use in high production operations. Never mount or secure any hand-held gun to a fixture or robot arm.

Air Requirements

For information describing the air pressure requirements, refer to the technical data supplied with the sealant gun..

Operation

Topics Covered in this Chapter

- ◆ Air-Powered Sealant Guns
- ◆ Manual Sealant Guns
- ◆ Pressure Relief Procedure

Air-Powered Sealant Guns

The 950 Series, air-powered sealant guns dispense adhesives or sealants from 2.5, 6 or 12 ounce polyethylene cartridges. Each size of these lightweight, all metal guns, is available in two styles: pistol grip and palm grip.

The guns feature an interchangeable gun body and actuator with a fast change cartridge knob included. The cartridge retainers are corrosion-resistant, will fit all handles and are made of high strength steel to prevent cartridge splitting under pressure.

In operation, the dispense rate is controlled through air pressure, trigger position and nozzle orifice. When the gun is actuated, air pressure forces the plunger down, inside the cartridge, forcing material out the nozzle. When the trigger is released, pressure is removed and dispensing stops.

Manual Sealant Guns



The manually-operated sealant gun for 2.5, 6 and 12 ounce cartridges uses a smooth plunger rod for easy operation. Simply releasing the trigger, releases the pressure; dispensing is easy to control and stops quickly.

Gun Tip/Nozzle Safety

Use extreme caution when cleaning or changing dispense sealant gun tips/nozzles. Always follow the **Pressure Relief Procedure** first, and then remove the spray tip/nozzle to clean it.

Never wipe off build-up around the tip/nozzle until pressure is relieved.

Pressure Relief Procedure

	
<p>This procedure describes how to relieve pressure for the sealant gun. To reduce the risk of serious injury, use this procedure whenever you shut off the sealant gun and before checking or adjusting any part of the sealant gun.</p>	

1. Shut off air supply to pump. Close any bleed-type master air valves.
2. Hold metal part of gun firmly to side of a grounded metal pail. Trigger gun to relieve pressure.

3. Open drain valve (required in your system) having a container ready to catch drainage.
4. Leave drain valve open until you are ready to dispense sealant again.

Note

If you suspect that the nozzle or hose is completely clogged, or that pressure has not been relieved fully after following the above steps, very slowly loosen the retaining nut or hose end coupling to relieve pressure gradually. Then loosen completely. Now clear the tip/nozzle or hose.

Troubleshooting

Problem	Cause	Solution
Gun fails to dispense when trigger is actuated.	Material lodged in nozzle	Follow Pressure Relief Procedure, page 5 . Clear nozzle of blockage.
	Material supply, hose, passages, clogged	Check material supply settings, hoses, etc. for proper material supply.
Seal leakage	Seals and packings are worn.	Rebuild gun as necessary using repair kit C04094.
Air leaks from gun inlet swivel.	Seals are worn	Replace seals using repair kit C04094.

Service

Topics Covered in this Chapter

- ◆ Sealant Gun Body Disassembly (C04093)
- ◆ Gun Handle Disassembly (C04079)
- ◆ Sealant Gun Reassembly (C04093)
- ◆ Gun Handle Assembly (C04079)

Sealant Gun Body Disassembly (C04093)

This procedure describes how to disassemble the sealant gun. Refer to Parts, page 8.

1. Shut off material and air supply lines to gun.
2. Actuate gun to purge material. Pressure Relief Procedure, page 5, from gun.
3. Disconnect air hose from sealant gun.
4. Unhook bracket (2) from retainer (21) and remove from sealant gun.
5. Disassemble parts attached to gun body as follows:
 - a. Cotter pin (3)
 - b. Knob and stud assembly (1)
 - c. Roll pin (10) and lever (17)
 - d. Snap ring (16) that holds the sleeve (15), two o-rings (14), push rod (13), o-ring (12), poppet (11) and spring (9) inside the body (4).
 - e. Unscrew the swivel screw (8) and remove the o-rings (14), swivel (6) and washer (5).

Note

The gun handle assembly should not be disassembled unless the original parts are worn or damaged.

Gun Handle Disassembly (C04079)

1. Remove the screw (101) and clamp (102) from the handle (103).
2. Carefully tap the spring pin (105) and trigger pin (106) out of the handle assembly.

3. Remove the trigger (107) and trigger spring (104) from the handle (103).

Sealant Gun Reassembly (C04093)

Note

- Clean all parts thoroughly before reassembling. Check them carefully for damage or wear, replacing parts if needed.
 - Repair Kit C04094 is available to service the Sealant Gun body. For best results, replace the original parts with new parts in the repair kit.
 - Prior to installation, lubricate all seals and o-rings with PARKER-O-LUBE™ or an equivalent lubricant. Check the material supplier for a compatible lubricant.
1. Clean and free all parts of solid material residue.
 2. Reassemble gun body as follows:
 - a. Install washer (5), swivel (6), two o-rings (14) and screw (8).
 - b. Install spring (9), poppet (11), o-ring (12), push rod (13), two o-rings (14), sleeve (15) and snap ring (16) inside body.
 - c. Install lever (17) and roll pin (10).
 - d. Install knob assembly (1) and bracket (2).
 - e. Install cotter pin (3).
 3. Hook bracket (2) onto the retainer (21). Install parts on the gun.
 4. Reconnect air hose to sealant gun.
 5. Turn on air supply to sealant gun. Check for leaks.

Gun Handle Assembly (C04079)

1. Place trigger (107) and trigger spring (104) inside handle (103). Make sure trigger spring is aligned correctly with trigger.
2. Insert spring pin (105) and trigger pin (106) into holes in handle (103) assembly.
3. Install clamp (102) and screw (101) in handle (103) assembly.

Parts

Palm Grip Guns

Size	Gun Part No.	Included Parts and Quantity	
		C04093 Sealant Gun Body Assembly	Retainer (21x) See Retainers Table, page 9
2.5 oz.	C04074	1	(21a) 1
6 oz.	C04087	1	(21b) 1

Pistol Grip Guns

Size	Gun Part No.	Included Parts and Quantity		
		C04093 Sealant Gun Body Assembly	C04079 Gun Handle Assembly	Retainer (21x) See Retainers Table, page 9.
2.5 oz.	C04076	1	1	(21a) 1
6 oz.	C04090	1	1	(21b) 1
12 oz.	C04068	1	1	(21c) 1

Model C04093 Sealant Gun Body Assembly

Ref. No.	Part No.	Description	Qty.
1	C04085	Knob and stud assembly	1
2	C04072	BRACKET	1
3	C19221	Cotter pin	1
4	C04101	Body	1
5	C04103	Washer	1
6	C04071	Swivel	1
7*	156454	O-ring	2
8	C04065	Swivel screw	1
9*	C04099	Spring	1

Ref. No.	Part No.	Description	Qty.
10*+	C20053	Roll pin	1
11*	C04096	Poppet	1
12*	C04100	O-ring	1
13	C04098	Push rod	1
14*	155685	O-ring	2
15	C04097	Sleeve	1
16*	C20404	Snap ring	1
17	C04086	Lever	1

* This part is included in Repair Kit C04094, which may be purchased separately.

Model C04079 Gun Handle Assembly

Ref. No.	Part No.	Description	Qty.
101	C19271	Screw	1
102	C04082	Clamp	1
103	C04080	Handle	1
104	C04083	Trigger spring	1

Ref. No.	Part No.	Description	Qty.
105	C20065	Spring pin	1
106	C20064	Trigger pin	1
107	C04081	Trigger	1

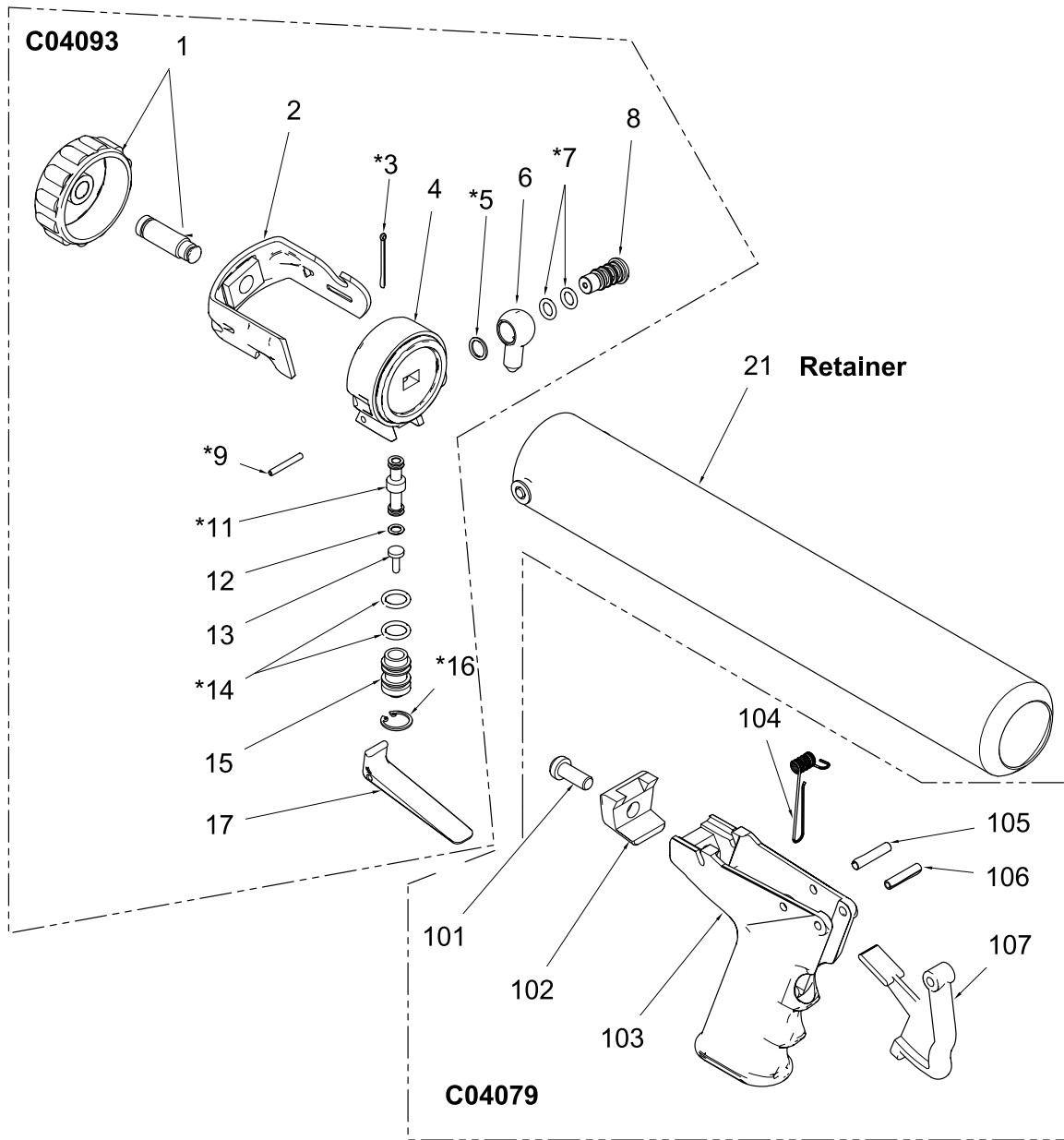

Retainers

Ref. No.	Part No.	Description
21a	C04077	2-1/2 oz. retainer (zinc plated)
21b	C04091	6 oz. retainer (zinc plated)
21c	C04069	12 oz. retainer (zinc plated)

Technical Data

Category	Data
Maximum working pressure	100 psi (7 MPa, 0.7 bar)
Outlet port size	1/4 npt(f)
Wetted parts	Polyethylene
Weight:	
Model C04068	1.52 lb (0.69 Kg) with tube
	1 lb. (0.45 Kg) without tube
Model C04076	1.07 lb. (0.48 Kg)
Model C04090	1.25 lb. (0.57 Kg)

Accessories

Brand	Part No.	Inlet Connector
Hansen	C04038	0.125 ID x 5 ft air hose with male Q.D. inlet
	C04026	0.125 ID x 10 ft air hose with male Q.D. inlet

Graco Standard Warranty

Graco warrants all equipment referenced in this document which is manufactured by Graco and bearing its name to be free from defects in material and workmanship on the date of sale to the original purchaser for use. With the exception of any special, extended, or limited warranty published by Graco, Graco will, for a period of twelve months from the date of sale, repair or replace any part of the equipment determined by Graco to be defective. This warranty applies only when the equipment is installed, operated and maintained in accordance with Graco's written recommendations.

This warranty does not cover, and Graco shall not be liable for general wear and tear, or any malfunction, damage or wear caused by faulty installation, misapplication, abrasion, corrosion, inadequate or improper maintenance, negligence, accident, tampering, or substitution of non-Graco component parts. Nor shall Graco be liable for malfunction, damage or wear caused by the incompatibility of Graco equipment with structures, accessories, equipment or materials not supplied by Graco, or the improper design, manufacture, installation, operation or maintenance of structures, accessories, equipment or materials not supplied by Graco.

This warranty is conditioned upon the prepaid return of the equipment claimed to be defective to an authorized Graco distributor for verification of the claimed defect. If the claimed defect is verified, Graco will repair or replace free of charge any defective parts. The equipment will be returned to the original purchaser transportation prepaid. If inspection of the equipment does not disclose any defect in material or workmanship, repairs will be made at a reasonable charge, which charges may include the costs of parts, labor, and transportation.

THIS WARRANTY IS EXCLUSIVE, AND IS IN LIEU OF ANY OTHER WARRANTIES, EXPRESS OR IMPLIED, INCLUDING BUT NOT LIMITED TO WARRANTY OF MERCHANTABILITY OR WARRANTY OF FITNESS FOR A PARTICULAR PURPOSE.

Graco's sole obligation and buyer's sole remedy for any breach of warranty shall be as set forth above. The buyer agrees that no other remedy (including, but not limited to, incidental or consequential damages for lost profits, lost sales, injury to person or property, or any other incidental or consequential loss) shall be available. Any action for breach of warranty must be brought within two (2) years of the date of sale.

GRACO MAKES NO WARRANTY, AND DISCLAIMS ALL IMPLIED WARRANTIES OF MERCHANTABILITY AND FITNESS FOR A PARTICULAR PURPOSE, IN CONNECTION WITH ACCESSORIES, EQUIPMENT, MATERIALS OR COMPONENTS SOLD BUT NOT MANUFACTURED BY GRACO. These items sold, but not manufactured by Graco (such as electric motors, switches, hose, etc.), are subject to the warranty, if any, of their manufacturer. Graco will provide purchaser with reasonable assistance in making any claim for breach of these warranties.

In no event will Graco be liable for indirect, incidental, special or consequential damages resulting from Graco supplying equipment hereunder, or the furnishing, performance, or use of any products or other goods sold hereto, whether due to a breach of contract, breach of warranty, the negligence of Graco, or otherwise.

FOR GRACO CANADA CUSTOMERS

The Parties acknowledge that they have required that the present document, as well as all documents, notices and legal proceedings entered into, given or instituted pursuant hereto or relating directly or indirectly hereto, be drawn up in English. Les parties reconnaissent avoir convenu que la rédaction du présent document sera en Anglais, ainsi que tous documents, avis et procédures judiciaires exécutés, donnés ou intentés, à la suite de ou en rapport, directement ou indirectement, avec les procédures concernées.

Graco Information

For the latest information about Graco products, visit www.graco.com.

To place an order, contact your Graco Distributor or call to identify the nearest distributor.

Phone: 612-623-6921 **or Toll Free:** 1-800-328-0211 **Fax:** 612-378-3505

All written and visual data contained in this document reflects the latest product information available at the time of publication. Graco reserves the right to make changes at any time without notice.

Original Instructions. This manual contains English. MM 309968

Graco Headquarters: Minneapolis

International Offices: Belgium, China, Japan, Korea

GRACO INC. P.O. BOX 1441 MINNEAPOLIS, MN 55440-1441

Copyright 2003, Graco Inc. is registered to ISO 9001; Revised 05/2011

www.graco.com